



Installation Guide

Linea™ Weatherboard

EXTERIORS

Australia August 2021

Make sure your information is up to date.

When specifying or installing James Hardie™ products, ensure that you have the current technical information and guides. If in doubt, or you need more information, visit www.jameshardie.com.au or Ask James Hardie™ on 13 11 03.



Installation Guide

Made in Australia

IMPORTANT NOTES

1. Failure to install, finish or maintain this product in accordance with applicable building codes, regulations, standards and James Hardie's written application instructions may lead to personal injury, affect system performance, violate local building codes, and void James Hardie's product warranty.
2. All warranties, conditions, liabilities (direct, indirect or consequential) and obligations whether arising in contract, tort or otherwise other than those specified in James Hardie's product warranty are excluded to the fullest extent allowed by law. For James Hardie's product warranty information and disclaimers about the information in this guide, visit www.jameshardie.com.au.
3. The builder must ensure the product meets aesthetic requirements before installation. James Hardie will not be responsible for rectifying aesthetic variations following installation.
4. Make sure your information is up to date. When specifying or installing James Hardie™ products, ensure you have the current guide. If in doubt, or you need more information, visit www.jameshardie.com.au, or Ask James Hardie™ on 13 11 03.

LINEA™ WEATHERBOARD AND AXENT™ TRIM SIZES









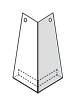

Product	Length (mm)	Width (mm)	Thickness (mm)	End details	COVERAGE INFORMATION				
					Effective cover (mm)	No. of planks /metre height	Mass kg/lin m	Mass kg/m ²	Pallet weight (90/pack) kg
150mm Linea™ weatherboard	4200*	150	16	T & G	120	8.3	2.8	23.2	1350
180mm Linea™ weatherboard	4200*	180	16	T & G	150	6.7	3.4	22.7	1620

Axent™ trim - Refer to current Axent™ trim guide for sizes.

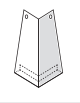

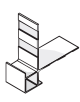
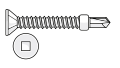
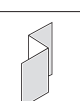
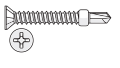

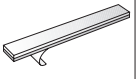

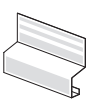
NOTES

1. All dimensions and masses provided are approximate only and subject to manufacturing tolerances. Masses are based on equilibrium moisture content of product.
2. *Length is 4200mm plus 5mm for the tongue and groove (T & G) making the length 4205mm overall.
3. Refer to page 3 for details of the effective cover and lapped thickness of the cladding.

ACCESSORIES / TOOLS SUPPLIED BY JAMES HARDIE

ACCESSORIES	DESCRIPTION	ACCESSORIES	DESCRIPTION
	Linea™ PVC starter strip 3,000mm long A perforated PVC starter strip used to set out the bottom edge of Linea™ weatherboards at the correct angle. 25 per pack. Part No. 305571		Linea™ Aluminium Universal Window Adaptor, 3,700mm long A ready to paint aluminium extrusion to be used adjacent to windows to finish the edge of Linea™ weatherboard. 5 per pack. Part No. 305510
	Linea™ Aluminium Corner Soaker for 150mm wide boards A ready to paint aluminium external corner soaker for use with 150mm wide Linea™ weatherboards. 100 per box. Part No. 305574		Hardie™ Joint Sealant. 300mL cartridge A general purpose, paintable, exterior grade polyurethane joint sealant. 20 per box. Part No. 305534
	Linea™ Aluminium Corner Soaker for 180mm wide boards A ready to paint aluminium external corner soaker for use with 180mm wide Linea™ weatherboards. 100 per box. Part No. 305572		Hardie™ Blade Saw Blade. 185mm diameter A 185mm diameter poly-diamond blade for fast and clean cutting of James Hardie™ fibre cement. 1 each. Part No. 300660
	Linea™ Aluminium External Slimline Boxed Corner, 3,600mm long A ready to paint aluminium extrusion to be used with Linea™ weatherboard to create external boxed corners. 40x40mm caps are available to seal the bottom. A 6mm hole must be drilled to release trapped water (supplied by others). 5 per pack. Part No. 305512		Hardie™ Drive Screw 41mm long A class 3 self-tapping wing-tipped screw for fastening to 0.5mm to 1.6mm BMT light gauge steel frames. 1000 per box. Part No. 305984
	Linea™ PVC Box Corner Z Flashing, 2,700mm long A PVC Z flashing for use with Linea™ weatherboard in conjunction with Axent™ trim to form external corners. 25 per pack. Part No. 305570		Hardie™ Drive Collated Screw 41mm long A class 3 self-tapping wing-tipped screw for fastening to 0.5mm to 1.6mm BMT light gauge steel frames. Suitable for use in most auto feed screw guns. 1000 per box. Part No. 305982
	Hardie™ 75x75mm Colorbond® Corner Flashing, 3,000mm long A Colorbond® corner flashing for use behind cladding at internal and external corners. 5 per pack. Part No. 305564		HardieBreak™ thermal strip A building code requirement and is installed behind James Hardie™ external cladding over metal framing and Hardie™ Wrap weather barrier. 42x12x2750mm. Refer to Hardie™ Break thermal strip installation guide. 45 per pack. Part No. 305612
	Hardie™ Wrap weather barrier A non-perforated, highly breathable and reflective safe-glare weather barrier designed to be used behind external cladding products to help protect the building. For alternate products, please refer to Hardie™ Wrap weather barrier section (p.2) Unit size 2750mm x 30000mm Part No. 305664.		Hardie™ Aluminium Internal corner mould 3600mm long 5pk A ready to paint aluminium extrusion to be used with Linea™ weatherboard to create internal corners. 5 per pack. Part No. 305511
			Hardie™ Edge Trim An architectural slab edge solution fabricated from high-quality powder coated aluminium. Base Trim unit size: 3950mm. Also available: Base Trim 4 per pack. Part No. 305911 Base Trim Jointer 12 per pack. Part No. 305912 Internal Corner 4 per pack. Part No. 305913 External Corner 4 per pack. Part No. 305914

COMPONENTS NOT SUPPLIED BY JAMES HARDIE James Hardie recommends the following products for use in conjunction with its Linea™ weatherboard and Axent™ trim. James Hardie does not supply these products and does not provide a warranty for their use. Please contact component the manufacturer for information on their warranties and further information on their products.

	40 x 2.8mm fibre cement nails For concealed fixing Linea™ weatherboard and various accessories to timber framing as specified.		Gun nails and nailers Suitable gun nails and nailers for concealed fixing to timber framing. Minimum nail length of 40mm is required.
	60 x 3.15mm bullet head nails For face fixing Linea™ weatherboard to timber framing as specified.		M class or higher vacuum Required to reduce the exposure to respirable dust and crystalline silica.
	Compound mitre saw with M class or higher vacuum extraction Dust reducing compound mitre saw used with Hardie™ Blade saw blade. Makita: LS0714/LS1013/LS1212 Hitachi: C10FSB/C12FSB		3.0mm dia drill bit For pre-drilling where required.

* Highly corrosive environments and areas within 1km of the coast require Class 4 or stainless steel coatings. Refer to the fastener manufacturer for recommendations.

WARNING - DO NOT BREATHE DUST AND CUT ONLY IN WELL VENTILATED AREA

James Hardie products contain sand, a source of respirable crystalline silica. **May cause cancer if dust from product is inhaled. Causes damage to lungs and respiratory system through prolonged or repeated inhalation of dust from product.**

Intact fibre cement products are not expected to result in any adverse toxic effects. The hazard associated with fibre cement arises from the respirable crystalline silica present in dust generated by activities such as cutting, rebating, drilling, routing, sawing, crushing, or otherwise abrading fibre cement, and when cleaning up, disposing of or moving dust.

When doing any of these activities in a manner that generates dust, follow James Hardie instructions and best practices to reduce or limit the release of dust, warn others in the area and consider rotating personnel across the cutting task to further limit respirable silica exposure.

If using a dust mask or respirator, use an AS/NZS1716 P1 filter and refer to Australian/New Zealand Standard 1715:2009 Selection, Use and Maintenance of Respiratory Protective Equipment for more extensive guidance and more options for selecting respirators for workplaces. For further information, refer to our installation instructions and Safety Data Sheets available at www.jameshardie.com.au. FAILURE TO ADHERE TO OUR WARNINGS, SAFETY DATA SHEETS, AND INSTALLATION INSTRUCTIONS MAY LEAD TO SERIOUS PERSONAL INJURY OR DEATH.

JAMES HARDIE RECOMMENDED SAFE WORKING PRACTICES

CUTTING OUTDOORS

1. Position cutting station so wind will blow dust away from the user or others in working area.
2. Warn others in the area to avoid dust.
3. Consider rotating personnel across cutting tasks to further limit respirable silica exposures.
4. Use one of the following methods based on the required cutting rate:
 - Best
 - Villaboard™ knife
 - Hand guillotine
 - Fibreshear
 - Better
 - Position the cutting station in a well-ventilated area.
 - Use a dust reducing circular saw equipped with Hardie™ Blade Saw Blade or comparable fibre cement blade and well maintained M-class vacuum or higher with appropriate filter for capturing fine (respirable) dust. Wear a properly-fitted, approved dust mask or respirator (minimum P1).

CUTTING INDOORS

- Cut only using Villaboard™ knife, hand guillotine or fibreshears (manual, electric or pneumatic).
- Position cutting station in a well-ventilated area.

DRILLING/OTHER MACHINING
When drilling or machining you should always wear a P1 dust mask and warn others in the immediate area.

IMPORTANT NOTES

1. For maximum protection (lowest respirable dust production) James Hardie recommends always using best practice cutting methods where feasible.
2. NEVER use a power saw indoors or in a poorly ventilated area.
3. ALWAYS use a dust reducing circular saw equipped with a sawblade specifically designed to minimise dust creation when cutting fibre cement - preferably a sawblade that carries the Hardie™ Blade logo or one with at least equivalent performance - connected to a M class or higher vacuum.
4. NEVER dry sweep - Use wet suppression, or an M class vacuum or higher with appropriate filter.
5. NEVER use grinders.
6. ALWAYS follow tool manufacturers' safety recommendations.
7. ALWAYS wear a properly fitted, approved dust mask, P1 or higher

DUST MASKS AND RESPIRATORS
As a minimum, an AS/NZS1716 P1 respirator must be used when doing any activity that may create dust. For more extensive guidance and options for selecting respirators for workplaces please refer to Australian/New Zealand Standard 1715:2009 "Selection, Use and Maintenance of Respiratory Protective Equipment". P1 respirators should be used in conjunction with the above cutting practices to minimise dust exposure. For further information, refer to Safety Data Sheet (SDS) available at www.jameshardie.com.au. If concern still exists about exposure levels or you do not comply with the above practices, you should always consult a qualified industrial hygienist or contact James Hardie for further information.

STORAGE AND HANDLING
To avoid damage, all James Hardie™ building products should be stored with edges and corners of the product protected from chipping. James Hardie™ building products must be installed in a dry state and protected from weather during transport and storage. The product must be laid flat under cover on a smooth level surface clear of the ground to avoid exposure to water, moisture, etc.

DESIGN

Compliance

All design and construction must comply with the appropriate requirements of the current National Construction Code (NCC), regulations and standards.

Responsibility

The specifier or other party responsible for the project must ensure that the details in this specification are appropriate for the intended application and that additional detailing is performed for specific design of any areas that fall outside the scope of this specification.

Slab and footings

The slab and footings on which the building is situated must comply with AS 2870 'Residential slabs and footings – Construction' and the requirements of the National Construction Code (NCC).

Ground clearances

Install James Hardie™ external cladding with a minimum 150mm clearance to the earth on the exterior of the building or in accordance with local building codes if greater than 150mm is required. Maintain a minimum 50mm clearance between James Hardie™ external cladding and roofs, decks, paths, steps and driveways.

Adjacent finished grade must slope away from the building in accordance with local building codes, typically a minimum slope of 50mm minimum over the first metre. Do not install external cladding such that it may remain in contact with standing water.

NOTE

Greater clearance may be required in order to comply with termite protection provisions, see below.

Termite protection

The National Construction Code (NCC) specifies the requirements for termite barriers and must be complied with. Where the exposed slab edge is used as part of the termite barrier system, a minimum of 75mm of the exposed slab edge must be visible to permit ready detection of termite entry.

Moisture management

It is the responsibility of designer or specifier to identify moisture related risks associated with any particular building design. Wall construction design must effectively manage moisture, accounting for both the interior and exterior environments of the building, particularly in buildings that have a higher risk of wind driven rain penetration or that are artificially heated or cooled.

In addition all wall openings, penetrations, junctions, connections, window sills, heads and jambs must incorporate appropriate flashing and waterproofing. Materials, components and their installation that are used to manage moisture in framed wall construction must, at a minimum, comply with the requirements of relevant standards and the NCC.

Structural bracing

Linea™ weatherboard can be used to achieve wall bracing. For more information refer to James Hardie's Structural Bracing Application Guide available at www.accel.com.au

Fire rated walls

Linea™ weatherboards clad walls can achieve fire ratings of 60/60/60 and 90/90/90 when constructed with additional fire rated linings as specified in James Hardie's Fire and Acoustically Rated Walls Application Guide & Technical Specification.

NOTE

Use 60 x 3.15 and 75 x 3.15mm corrosion resistant bullet head nails for concealed and face fixing respectively in fire rated applications.

FRAMING

General

Linea™ weatherboard may be specified for timber-framed or steel-framed structures. Stud spacings for Linea™ cladding for the wind load classifications of AS 4055 'Wind Loads for Housing' are given in Table 1.

TABLE 1

MAXIMUM STUD SPACING			
WIND CLASSIFICATION		STUD SPACING	
Non-cyclonic	Cyclonic	General areas of building (mm)	Within 1200mm of building edges (mm)
N1, N2, N3	C1	600	600
N4, N5	C2, C3	600	450
N6	C4	450	300

Timber framing

Dimensions

A 35mm minimum stud width is required.

Structural grade

Use only seasoned timber. Unseasoned timber must not be used because it is prone to shrinkage and can cause planks and frames to move.

Durability

'Timber used for house construction must have the level of durability appropriate for the relevant climate and expected service life and conditions including exposure to insect attacks or to moisture, which could cause decay.' Reference AS 1684.2 'Residential timber-framed construction'.

Frame construction

Use of timber framing must be in accordance with AS 1684 and the framing manufacturer's specifications. Stud spacings must be in accordance with Table 1.

NOTE: When using 70mm deep framing it is recommended that the Linea™ weatherboard be installed prior to plumbing, electrical and other services within the frame. This will prevent these services being damaged by fasteners used to install the Linea™ weatherboard.

Steel framing

Dimensions and gauge

A 35mm minimum stud width is required. Framing members must be in the range 0.55 to 1.6mm BMT (base metal thickness).

Steel

Use of steel framing must be in accordance with NASH standard for Residential and Low-Rise Steel Framing Part 1: Design Criteria and the framing manufactures specifications. Framing members must have the appropriate level of durability required to prevent corrosion.

Thermal Break

For steel frames, the Building Code of Australia sections J1.5 and 3.12.1 volumes 1 and 2 respectively, state for both residential and commercial buildings a thermal break with an R 0.2m² K/W must be installed behind external cladding where the cladding and internal lining make direct contact with the same steel frame. For information relating to the suitability of James Hardie's Hardie™ Break thermal strip, refer to the Hardie™ Break Installation Guide at www.jameshardie.com.au

Stud spacings must be in accordance with Table 1.

Special framing requirements

The following are special framing requirements for both timber and steel framing:

- Additional framing may be required at internal corners and sides of openings, see relevant details on the following pages.
- Extra depth lintels may be necessary for fixing of head flashing and trim. Lintels must be located in

the frame flush externally to adequately support the head flashing and trim.

- Extra packers at external corners for use with Axent™ trim boxed corners.

Tolerances

Ensure frame is square and work from central datum line. Frames must be straight and true to provide a flush face to receive the Linea™ weatherboard. A suggested maximum tolerance of between 3mm and 4mm in any 3000mm length of frame will give best results. Linea™ weatherboard will not straighten excessively warped or distorted frames and any warping may still be visible after product is applied.

PREPARATION

Weather Barrier

A suitable water control membrane must be installed under James Hardie™ cladding in accordance with the AS/NZS 4200.2 'Pliable building membranes and underlays – Installation' and NCC requirements.

James Hardie has tested and certified the use of Hardie™ Wrap weather barrier for climate zones 2-8 within Australia. Hardie™ Wrap weather barrier is a Class 4 vapour permeable membrane that delivers a triple-shield of protection to help against external weather penetration, internal condensation management and external heat penetration through its safe-glare reflective layer.

If using an alternate product in lieu of Hardie™ Wrap weather barrier or the project is located in a hot humid area (Climate Zone 1), the designer must ensure that the product is fit for purpose and it has the following classification in accordance with AS/NZS 4200.1:2017 'Pliable building membranes and underlays – Materials':

WEATHER BARRIER CLASSIFICATION		
CLIMATE ZONES	WATER BARRIER	VAPOUR PERMEANCE
2-8	High	Vapour permeable (Class 3 or 4)
1		Vapour Barrier (Class 1 or 2)

Soft compressible insulation installed between the front of the wall studs and directly behind the external cladding can cause installation issues and is thus not recommended.

Flashing

All wall openings, penetrations, intersections, connections, window sills, heads and jambs must be flashed prior to plank installation. See 'Moisture Management' Section for requirements.

Accessories

Some Linea™ weatherboard accessories may require installation prior to fixing of the boards. Refer to the relevant details in this document.

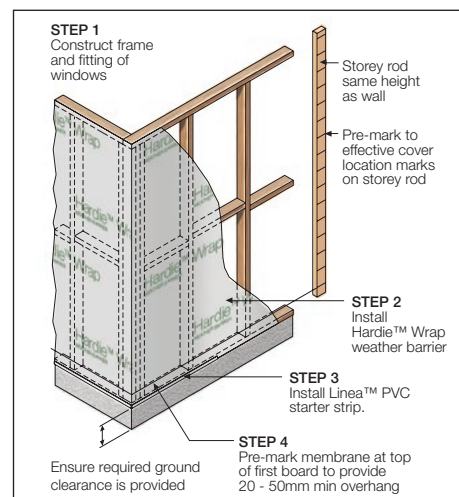

NOTES

1. Ensure all double studs are well nailed together, and flush at the outside face.
2. Generally external and internal corners have additional framing requirements and require that flashings and/or components are fitted prior to fixing the Linea™ weatherboard.
3. Ensure aluminium corner accessories are installed prior to Linea™ weatherboard installation.
4. Alternative methods can be used to gauge the effective cover during installation e.g. marking corner moulds or using timber blocks cut to effective cover height to locate and support boards.

INSTALLATION

NOTE

You must ensure the product is of acceptable quality prior to installation, see Important Note 3. Install the cladding as detailed below around the building, joining the boards at the tongue and groove progressively.

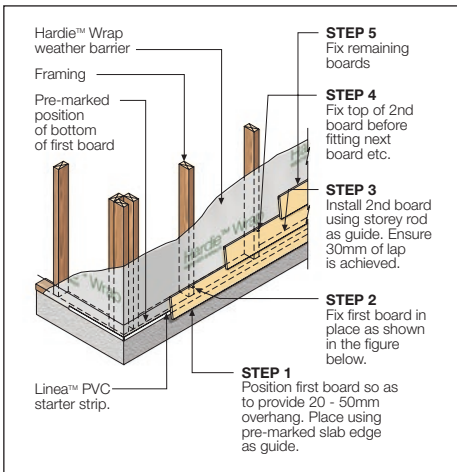

NOTES

1. Boards should be nailed to the studs starting from the centre of the board outwards.
2. Select an off-cut to start the second course at the corner so that joints are staggered.

SLAB / EAVE JUNCTION

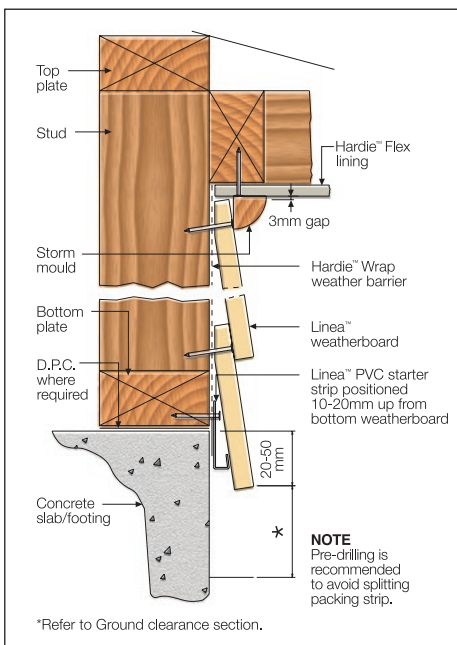

SLAB JUNCTION ALTERNATIVE

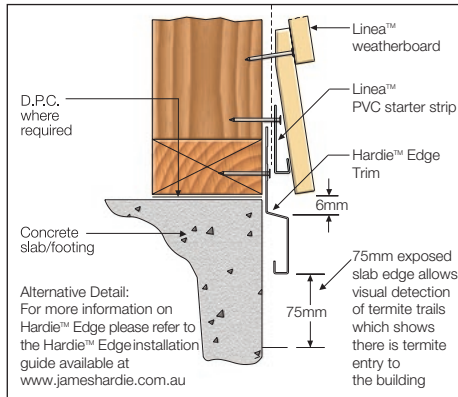

FIXING

Linea™ weatherboard is installed with 40 x 2.8mm fibre cement nails by concealed fixing as shown below. Suitable gun nails of 40mm minimum length can also be used.

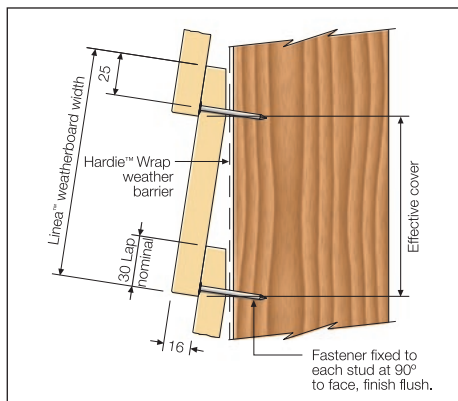

Face fixing must be provided for bracing applications as shown below.

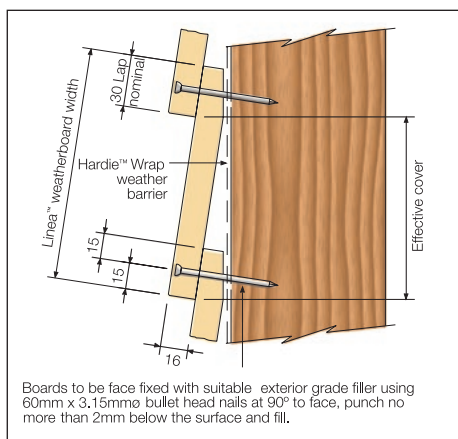

NOTES

1. Hold the board hard to the stud when fixing.
2. Face fixing may be added whenever site conditions create undue gaps between boards at laps. Alternatively corrosion resistant 25 mm lap nails can be used to minimise gaps by face fixing where required.
3. The minimum edge distance to the end of the board is 20mm for hand nailing and 50mm for gun nailing.
4. If fixing is to be carried out using a nail gun, ensure that the appropriate size and fastener durability is selected. Gun nailing is not recommended for face fixing applications.
5. Nail guns must be set to ensure that the nails are flush with the surface of the boards. Gun nails may require extra nailing by hand.

6. Face fixing method must be used if structural bracing required.
7. Longer fasteners may be required for fire rated applications, refer to James Hardie's Fire and Acoustically Rated Walls Application Guide.

FASTENERS

Fastener durability

Fasteners must have the appropriate level of durability required for the intended project. This is of particular importance in coastal areas, areas subject to salt spray and other corrosive environments.

Fasteners must be fully compatible with all other materials that they are in contact with to ensure the durability and integrity of the assembly.

Contact fastener manufacturers for more information.

Fasteners for timber

NOTE

The minimum edge distance to the end of the board is 20mm and 50mm for hand and gun nailing respectively.

Hand nailing

Linea™ weatherboard must be fixed to timber framing with the types of nails shown in Table 2. Refer to Axent™ Trim Installation Instructions for trim fixing details.

TABLE 2

NAIL REQUIREMENTS FOR LINEA™ WEATHERBOARD	
CONCEALED NAILING	
40 x 2.8mm fibre cement nail	Class 3 minimum finished flush with board surface.
FACE NAILING	
60 x 3.15mm bullet head nails	Class 3 minimum nails may be driven through both thicknesses at board lap without pre-drilling. Stainless steel nails will require pre-drilling. Use a 3.0mm drill bit.

Gun nailing

A variety of gun nails are available for concealed nailing of Linea™ weatherboard using various guns. Nails must be a minimum of 40mm long, contact supplier for details.

Fasteners for steel

Linea™ weatherboard must be fixed to 0.55 – 1.6mm BMT domestic type steel framing with the types of screws shown in Table 3.

TABLE 3

SCREW REQUIREMENTS FOR LINEA™ WEATHERBOARD	
CONCEALED SCREWING	
41mm Hardie™ Drive	A class 3 self-tapping wing-tipped screw for fastening to 0.5mm to 1.6mm BMT light gauge steel frames.
FACE SCREWING	
52mm special wing screw by TRI-FIXX	For 0.55 - 1.2mm BMT steel framing. Available in Class 3 (hot-dipped galvanised) and stainless steel.

* Highly corrosive environments and areas within 1km of the coast require Class 4 or stainless steel coatings. Refer to the fastener manufacturer for recommendations.

Fasteners should be driven flush as shown below.

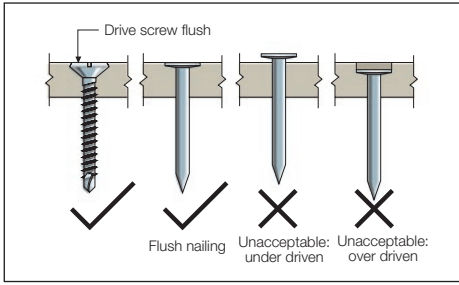

JOINTING

The ends of Linea™ weatherboard are jointed off-stud by means of the tongue-and-groove joint.

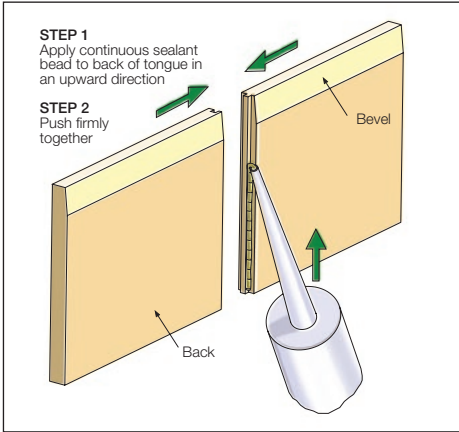
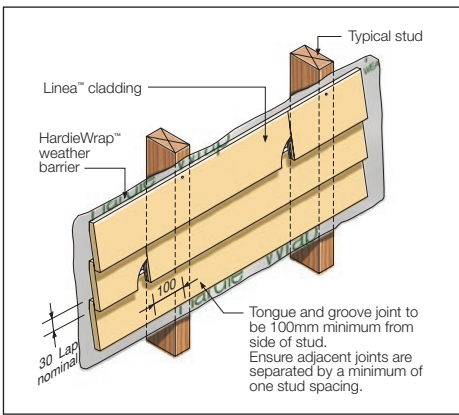

EXTERNAL CORNERS

Axent™ trim external corner

NOTE: Refer to Axent™ trim Installation Instructions for installation information.

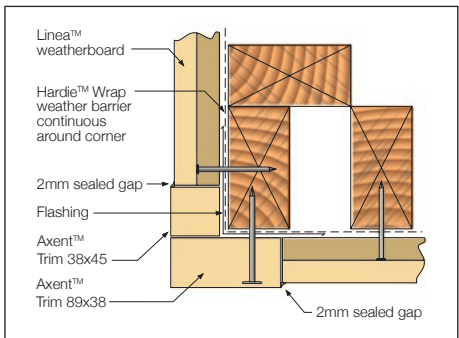

Slimline box corner

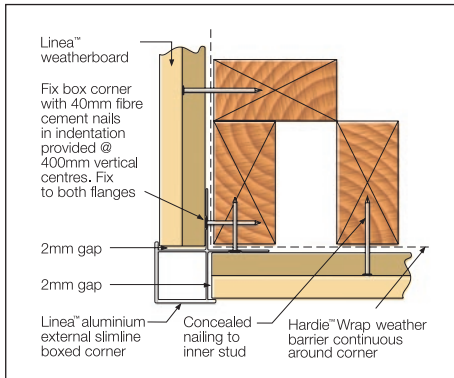
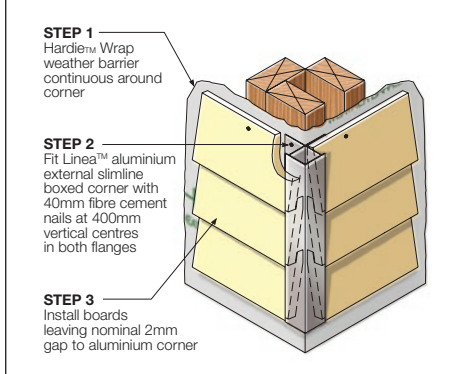

Corner soakers

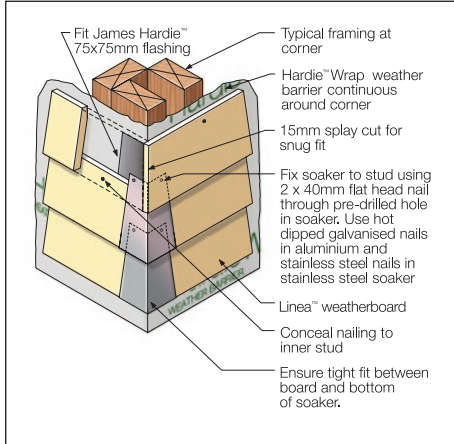

External mitre corner

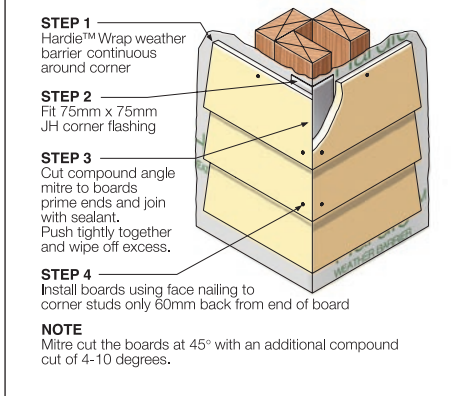

INTERNAL CORNERS

Axent™ trim internal corner

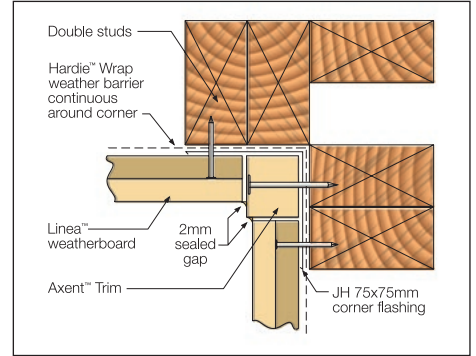

Internal corner mould

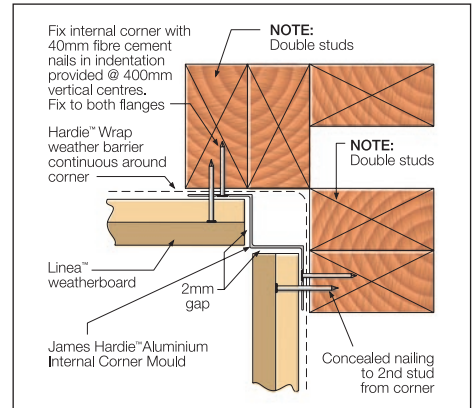
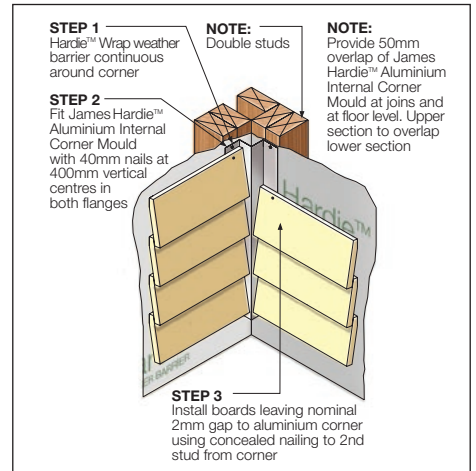

NOTCH AND SCRIBE

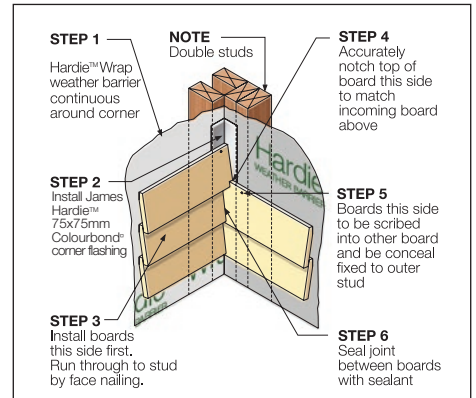

WINDOWS

Windows using Axent™ trim

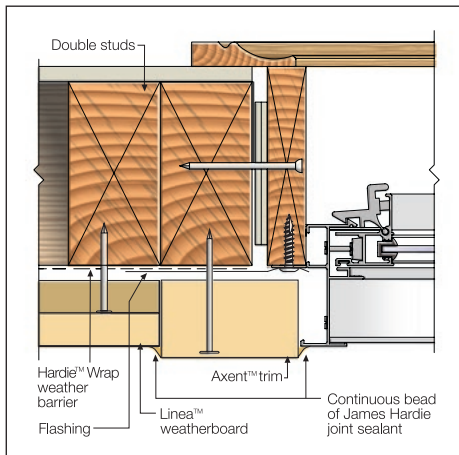
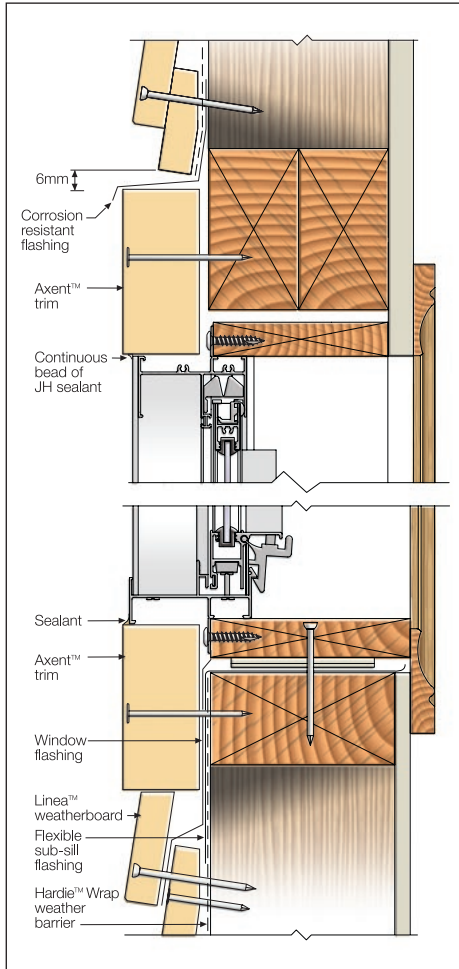

Windows using the Linea™ Aluminium Window Adapter

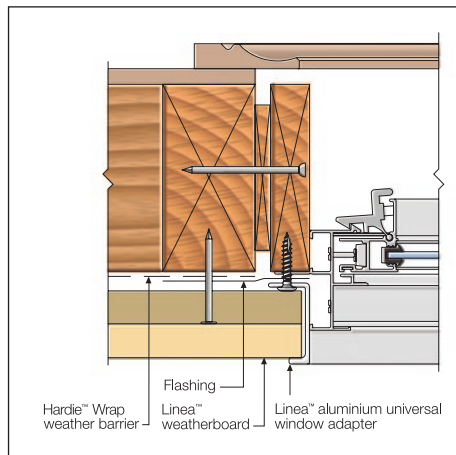
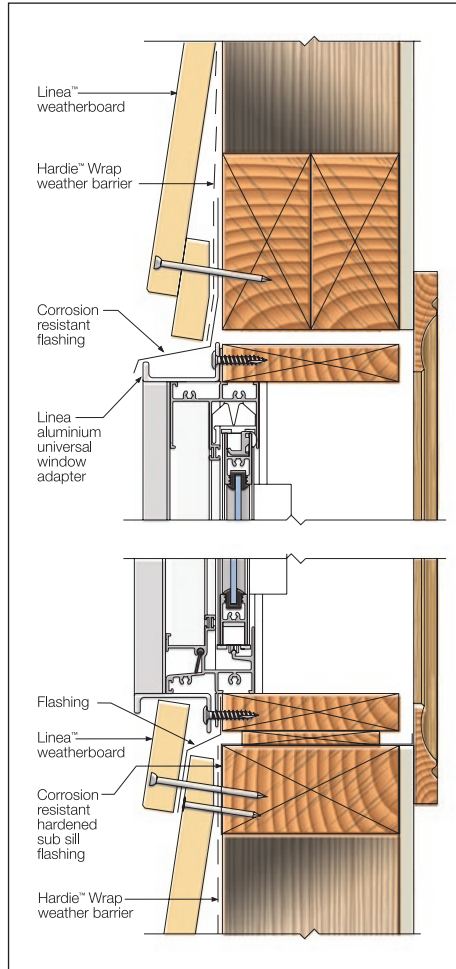

FINISHING

Preparation and priming

The Linea™ weatherboard and Axent™ trim are pre-primed and must be dry before painting. Punch and fill all exposed nails a maximum of 2mm below the surface of the board. For screws, ensure the head of the screw is nominally 2mm below the surface of the board.

Fill the hole with a suitable exterior grade filler, allow to cure and sand smooth. Priming of filled and sanded patches may be required in accordance with paint manufacturer's specifications.

NOTE: Care must be taken not to over-sand as it can affect the finish.

Sealants

Application and use of sealants must comply with manufacturer's instructions. Sealants, if coated, must be compatible with the paint system. James Hardie recommends the use of Hardie™ joint sealant, which is a paintable polyurethane sealant.

Painting

Refer to the project specification for paint requirements. The Linea™ weatherboard and Axent™ trim are pre-primed must be painted within 3 months of being fixed. James Hardie recommends the application of two coats minimum of a quality acrylic paint over the pre-primed boards in accordance with the paint manufacturer's specifications. Some environments require special coatings. Painting selection and specifications are dependant on the paint chosen. Refer to the paint manufacturer for information and details of their warranty.

Staining

Stains containing linseed oil are specifically designed for wood and may not be suitable for James Hardie™ cladding products, primed or unprimed. Semi-transparent stains can vary in uniformity of appearance depending on method of application and conditions and will require a high level of skill and craftsmanship to achieve a uniform appearance. Clear coats have not proven durable in exterior exposure and James Hardie considers them a maintenance item that may require application of a refurbishing sealer at regular intervals. James Hardie does not warrant the appearance or durability of semi-transparent stains and clear coats.

MAINTENANCE

The extent and nature of maintenance will depend on the geographical location and exposure of the building. As a guide, it is recommended that basic normal maintenance tasks shall include but not be limited to:

- Washing down exterior surfaces every 6-12 months*
- Re-applying of exterior protective finishes*
- Maintaining the exterior envelope and connections including joints, penetrations, flashings and sealants that may provide a means of moisture entry beyond the exterior cladding.
- Ensure clearances specified in this document is maintained.
- Cleaning out gutters, blocked pipes and overflows as required.
- Pruning back vegetation that is close to or touching the building.

*Refer to your paint manufacturer for washing down and recoating requirements related to paint performance.

PRODUCT INFORMATION

General

The basic composition of James Hardie™ building products is Portland cement, ground sand, cellulose fibre, water and proprietary additives.

James Hardie™ building products are manufactured AS/NZS 2908.2 'Cellulose-Cement Products-Flat Sheet'. These are also compliant with equivalent standard ISO 8336 'Fibre-cement flat sheets - Product specification and test methods'. For product classification refer to the relevant Physical Properties Data Sheet.

Durability

Resistance to moisture/rotting

Linea™ weatherboard and Axent™ trim has demonstrated resistance to permanent moisture-induced deterioration (rotting) by passing the following tests in accordance with AS/NZS 2908.2:

- Water permeability (Clause 8.2.2)
- Warm water (Clause 8.2.4)
- Heat rain (Clause 6.5)
- Soak dry (Clause 8.2.5).

Resistance to fire

Linea™ weatherboard and Axent™ trim are suitable where non-combustible materials are required in accordance with C1.9 of the Building Code of Australia.

James Hardie™ building products have been tested by CSIRO in accordance with AS/NZS 3837 and are classified as conforming to Group 1 material (highest and best result possible), with an average specific extinction area far lower than the permissible 250m²/kg, as referenced in Specification C1.10a of the National Construction Code (NCC).

Resistance to termite attack

Based on testing completed by CSIRO Division of Forest Products and Ensis Australia James Hardie™ building products have demonstrated resistance to termite attack.

Alpine regions

In regions subject to freeze/thaw conditions, all James Hardie™ fibre cement external cladding must be installed and painted in the warmer months of the year where the temperature does not create freeze and thaw conditions or paint issues. The cladding must be painted immediately after installation. In addition, fibre cement cladding must not be in direct contact with snow and/or ice build up for extended periods, e.g. external walls in alpine regions subject to snow drifts over winter.

Furthermore, a reputable paint manufacturer must be consulted in regards to a suitable product, specifications and warranty. The paint application must not be carried out if the air temperature or the substrate temperature is outside the paint manufacturer's recommendation including the specified drying temperature range

James Hardie™ external cladding products are tested for resistance to frost in accordance with AS/NZS 2908.2 Clause 8.2.3

Ask James Hardie™
Call 13 11 03
www.jameshardie.com.au

Notes

Notes

Notes

Notes



**For information and advice
call 13 11 03 | jameshardie.com.au**

Australia August 2021

© 2021 James Hardie Australia Pty Ltd ABN 12 084 635 558
™ and © denote a trademark or registered mark owned by James Hardie Technology Limited.

